

revolutionary dispensing solutions

MODD and BODD

The automatic drain, enzyme or bacteria dosing system

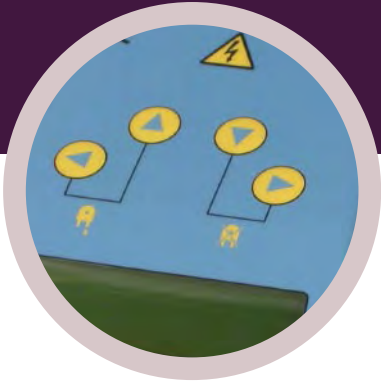

The MODD (mains operated drain doser) and BODD (battery operated drain doser) are automatic dosing systems that provide the timed delivery of a single product. They are controlled by a real time clock and offer up to eight programmable timing entries. Programming is achieved using an external membrane with security access protection and is viewed on an alphanumeric display. The BODD incorporates a compensation facility that will increase the pump run time in relation to the reduction in battery power in order to maintain a constant dose. A battery life indicator is also available on the display.

revolutionary dispensing solutions

MODD and BODD

MODD 200

As an alternative unit to the MODD, the MODD 200 provides increased flexibility. In addition to the features of the MODD, the MODD 200 utilises the Brightstaltic Double Pumphead that offers the ability to dose two products and has an increased flowrate of 210ml/min (with 5mm Silicone using water).



Features and benefits

- Membrane programming simple with security access code, includes prime and pump stop
- New enclosure screw-less locking and hinged front for easy access
- Customisable plaque printable area for company logo
- Disposable pumphead simple replacement, variety of tube materials
- Equal flowrate equal performance from battery and mains version
- Internal back-up battery maintains settings for up to 6 months without power
- Battery indicator (BODD) view remaining life with low battery warning
- Battery low' compensate (BODD) run time increases as battery power reduces
- IP66 enclosure prevents ingress of dust and water
- Full CE approval and EMC compliance

Operation

The unit has eight available timing entries consisting of a start time and duration. These timing entries can be selected to operate on any combination of days of the week. Preset combinations are available for every day, weekdays only and weekends only. Once the unit is set with the current time and day, the pump will operate at the programmed time and duration, on the selected days. Total run time and cycle counters for the pump are also available.

- MODD - 230V AC (other voltages on request)
- BODD - 4 x D-Cell batteries (not included)

Power	MODD 230V AC 50/60Hz, 10mA Maximum, 2.5W Maximum BODD 6V DC (4 x D cell batteries), 0.4A Maximum, 2.5W Maximum
Signals	N/A
Pumphead	Disposable Mini Pumphead with Silicone tube as standard Other materials available on request
Flowrate	MODD 5mm Silicone 75ml/min (using water) BODD 5mm Silicone 75ml/min (using water)
Control Circuitry	Microprocessor controller with 16x2 Alphanumeric LCD display Programming via 4 external membrane keys, Security access code
Motor	6V DC, 400mA with 80 RPM gearbox
Enclosure	IP66M water resistant, robust, ABS injection moulded enclosure and plaque
Installation Kit	Available on request
Approvals	EMC 89/336/EEC - EN61000-6-3:2001:EN61000-6-1:2001 LVD 72/23/EEC - EN60335-1
Packaging Dimensions(mm)	Single unit - 290 x 220 x 220
Weight(approx.)	Single unit - 1.0kg
Order Reference	MODD BODD

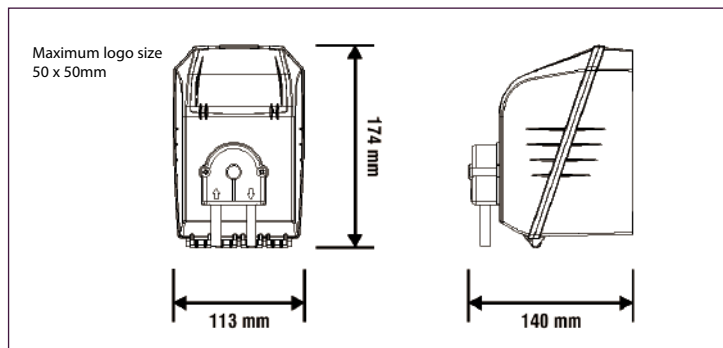

your local stockist:

EQUIPE SOLUTIONS pty Ltd
dispensing innovation

Australian Office: 201 Main North Road, Nailsworth SA 5008
 phone: 1300 788 250
 fax: 1300 668 515
 email: enquiries@brightwell.net.au
 web: www.brightwell.net.au